

FEATURES

- Output Current up to 6A
- 2:1 Wide Input Voltage Range
- Six-Sided Continuous Shielding
- 20 Watts Maximum Output Power
- Options: Negative Logic Remote ON/OFF
- **Call Factory for More Output Power Options**
- Compliant to RoHS EU Directive 2002/95/EC
- CE Mark Meets 2006/95/EC, 93/68/EEC, and 89/336 EEC
- Chassis Mount Options: Open Frame, U Channel, and Enclosed Types Available

APPLICATIONS

- Measurement
- Wireless Network
- Telecom/Datacom
- Industry Control System
- Semiconductor Equipment

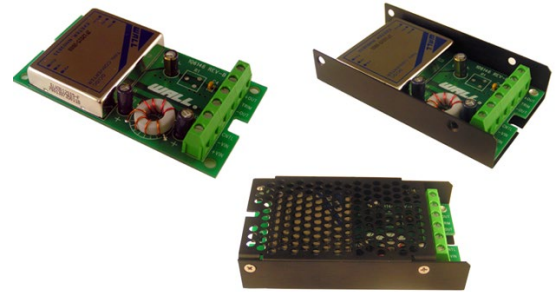

SPECIFICATIONS: CMMD Series

All specifications apply @ 25°C ambient unless otherwise noted

INPUT SPECIFICATIONS

Input Voltage Range.....	12V nominal input	9-18VDC
	24V nominal input	18-36VDC
	48V nominal input	36-75VDC
Input Voltage Variation	dv/dt	5V/ms max (Complies with ETS300 132 part 4.4)
Input Surge Voltage (100ms max)	12V input.....	36VDC
	24V input.....	50VDC
	48V input.....	100VDC
Input Reflected Ripple Current (nominal Vin and full load).....		20mA _{p-p}
Start Up Time (nominal Vin and constant resistive load)		
Power Up.....		10ms typ.
Remote ON/OFF		10ms typ.
Remote ON/OFF (Note 6)		
(Positive Logic).....	DC-DC ON	Open or 3V < Vr < 12V
	DC-DC OFF	Short or 0V < Vr < 1.2V
(Negative Logic)	DC-DC ON	Short or 0V < Vr < 1.2V
	DC-DC OFF	Open or 3V < Vr < 12V
Input Current of Remote Control Pin (nominal Vin).....		-0.5mA ~ +0.5mA
Remote Off Input Current (nominal Vin)		2.5mA

OUTPUT SPECIFICATIONS

Output Voltage	see table
Voltage Accuracy (nominal Vin and full load).....	±1%
Voltage Adjustability	10%
Output Current	see table
Output Power	20 watts max.
Line Regulation (LL to HL at FL).....	±0.2%
Load Regulation (no load to full load)	±0.5%
Minimum Load.....	0%
Ripple/Noise (20 MHz BW).....	see table
(measured with a 0.1uF/50V MLCC)	
Temperature Coefficient.....	±0.02% / °C max.
Transient Response Recovery Time (25% load step).....	250us

PROTECTION SPECIFICATIONS

Over Voltage Protection	1.5, 1.8, 2.5, 3.3V outputs	3.9V
(zener diode clamp)	5V output.....	6.2V
	12V output.....	15V
	15V output.....	18V
Over Load Protection (% of full load at nominal input)		150% max.
Short Circuit Protection.		Hiccup, automatic recovery

GENERAL SPECIFICATIONS

Efficiency	see table
Switching Frequency.....	500KHz typ.
Isolation Voltage (Input to Output).....	1600VDC min.
Isolation Voltage (Input to case).....	1600VDC min.
Isolation Voltage (Output to Case).....	1600VDC min.
Isolation Resistance	10 ⁹ ohms min.
Isolation Capacitance.....	1000pF max.

ENVIRONMENTAL SPECIFICATIONS

Operating Temperature.....	-40°C ~ +85°C (with derating)
Storage Temperature	-55°C ~ +105°C
Maximum Case Temperature	100°C
Relative Humidity	5% to 95% RH
Thermal Impedance (Note 7)	
Natural Convection.....	12°C / Watt
Natural Convection with Heat-Sink	10°C / Watt
Thermal Shock.....	MIL-STD-810F
Vibration.....	10~55Hz, 10G, 30 minutes along X, Y, and Z
MTBF (Note 1).....	1.791 x 10 ⁶ hours

PHYSICAL SPECIFICATIONS

Potting material of the DC/DC Converter.....	Epoxy (UL94-V0)
Shielding of the DC/DC Converter.....	six-sided
Weight	Approximately 6oz
Dimensions	4.00(L) x 2.25(W) x 0.81(H) inches

SAFETY & EMC

Approvals and Standards.....	IEC60950-1, UL60950-1 (See Note 9), EN60950-1		
EMI	EN55022	Class A	
ESD	EN61000-4-2	Air ± 8KV	Perf. Criteria B
		Contact ± 6KV	
Radiated Immunity	EN61000-4-3	10V/m	Perf. Criteria A
Fast Transient.....	EN61000-4-4	±2KV	Perf. Criteria B
Surge.....	EN61000-4-5	±1KV	Perf. Criteria B
Conducted Immunity ..	EN61000-4-6	10 Vrms	Perf. Criteria A

Due to advances in technology, specifications subject to change without notice

OUTPUT VOLTAGE / CURRENT RATING CHART

Model Number	Input Range	Output Voltage	Output Current		Output (4) Ripple & Noise	Input Current		Eff (4) (%)	Capacitor (5) Load max
			Min. Load	Full Load		No load (3)	Full load (2)		
CMMD12S1.5-6000	12VDC (9 – 18 VDC)	1.5 VDC	0mA	6000mA	60mVp-p	70mA	1014mA	78	6500uF
CMMD12S1.8-6000		1.8 VDC	0mA	6000mA	60mVp-p	75mA	1200mA	79	6500uF
CMMD12S2.5-6000		2.5 VDC	0mA	6000mA	60mVp-p	80mA	1582mA	83	3300uF
CMMD12S3.3-5000		3.3 VDC	0mA	5000mA	60mVp-p	115mA	1698mA	85	1300uF
CMMD12S5-4000		5 VDC	0mA	4000mA	75mVp-p	75mA	2008mA	87	6800uF
CMMD12S12-1670		12 VDC	0mA	1670mA	75mVp-p	90mA	2037mA	86	2200uF
CMMD12S15-1330		15 VDC	0mA	1330mA	75mVp-p	35mA	2027mA	86	755uF
CMMD24S1.5-6000	24VDC (18 – 36 VDC)	1.5 VDC	0mA	6000mA	60mVp-p	35mA	493mA	80	6500uF
CMMD12S1.8-6000		1.8 VDC	0mA	6000mA	60mVp-p	45mA	584mA	81	6500uF
CMMD24S2.5-6000		2.5 VDC	0mA	6000mA	60mVp-p	40mA	781mA	84	3300uF
CMMD24S3.3-5000		3.3 VDC	0mA	5000mA	60mVp-p	30mA	838mA	86	1300uF
CMMD24S5-4000		5 VDC	0mA	4000mA	75mVp-p	35mA	980mA	89	6800uF
CMMD24S12-1670		12 VDC	0mA	1670mA	75mVp-p	55mA	1006mA	87	2200uF
CMMD24S15-1330		15 VDC	0mA	1330mA	75mVp-p	40mA	1002mA	87	755uF
CMMD48S1.5-6000	48VDC (36 – 75 VDC)	1.5 VDC	0mA	6000mA	60mVp-p	15mA	247mA	80	6500uF
CMMD48S1.8-6000		1.8 VDC	0mA	6000mA	60mVp-p	20mA	288mA	82	6500uF
CMMD48S2.5-6000		2.5 VDC	0mA	6000mA	60mVp-p	30mA	391mA	84	3300uF
CMMD48S3.3-5000		3.3 VDC	0mA	5000mA	60mVp-p	15mA	414mA	87	1300uF
CMMD48S5-4000		5 VDC	0mA	4000mA	75mVp-p	20mA	490mA	89	6800uF
CMMD48S12-1670		12 VDC	0mA	1670mA	75mVp-p	35mA	497mA	88	2200uF
CMMD48S15-1330		15 VDC	0mA	1330mA	75mVp-p	50mA	501mA	87	755uF

NOTES

1. BELLCORE TR-NWT-000332. Case 1: 50% Stress, Temperature at 40°C. (Ground fixed and controlled environment).
2. Maximum value at nominal input voltage and full load.
3. Typical value at nominal input voltage and no load.
4. Typical value at nominal input voltage and full load.
5. Test by minimum Vin and constant resistive load.
6. The ON/OFF control pin voltage is referenced to -Vin.
To order Negative Logic ON-OFF Control add the suffix-R (Ex: CMMD48S12-1670R).
7. Heat sink is optional. Contact Factory for ordering details.
8. Chassis Mount Options: No suffix for open frame, "U" suffix for U Channel, and "E" suffix for Enclosed type.
9. This product is Listed to applicable standards and requirements by UL.

DERATING CURVES & EFFICIENCY GRAPHS

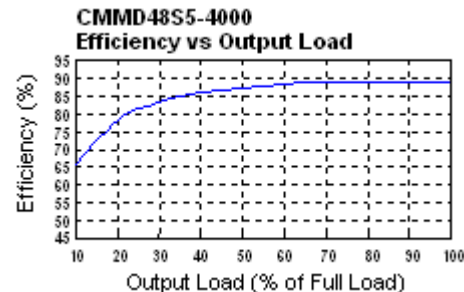
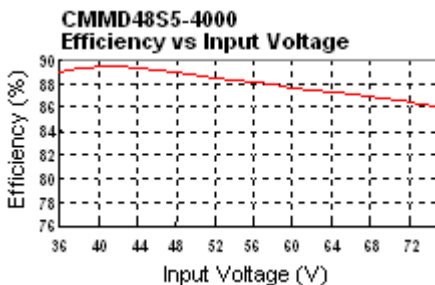
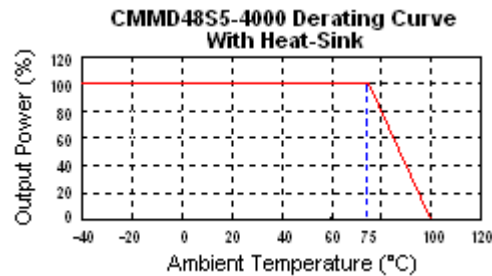
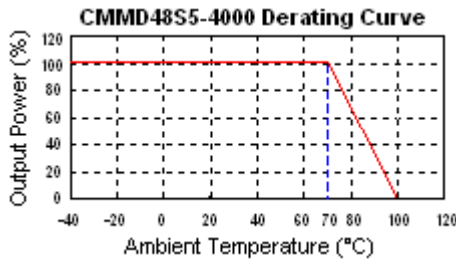

MECHANICAL DRAWING

Unit: inches [mm]

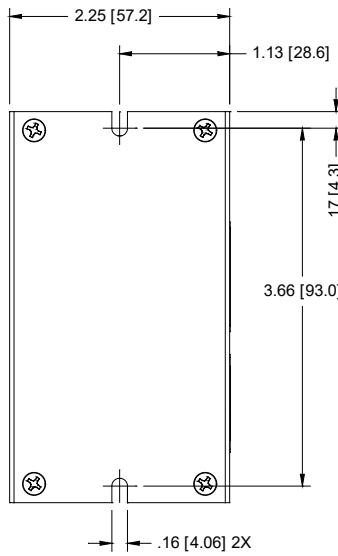
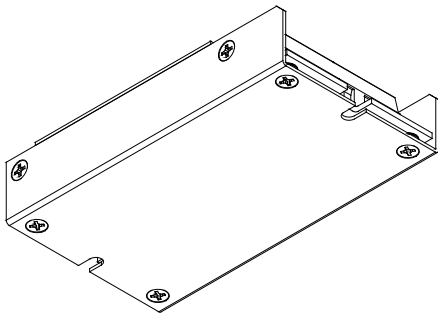
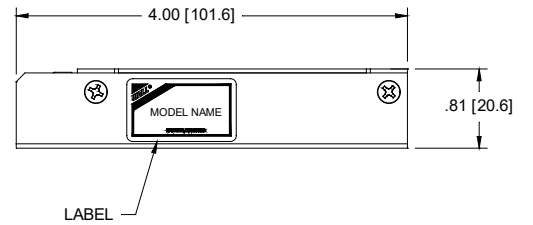
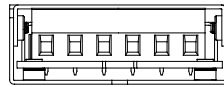
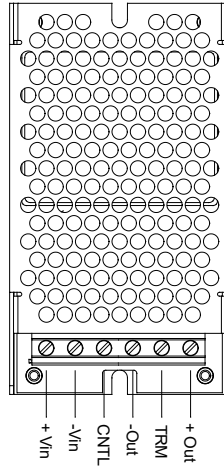
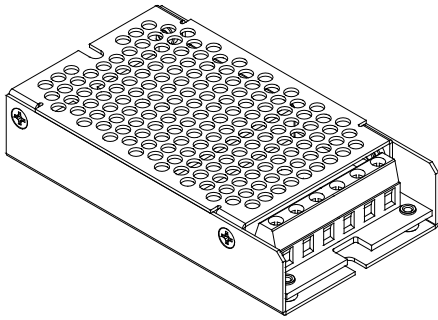

COMPANY INFORMATION

Wall Industries, Inc. has created custom and modified units for over 50 years. Our in-house research and development engineers will provide a solution that exceeds your performance requirements on-time and on budget. Our ISO9001 certification is just one example of our commitment to producing a high quality, well-documented product for our customers.

Our past projects demonstrate our commitment to you, our customer. Wall Industries, Inc. has a reputation for working closely with its customers to ensure each solution meets or exceeds form, fit and function requirements. We will continue to provide ongoing support for your project above and beyond the design and production phases. Give us a call today to discuss your future projects.

Contact **Wall Industries** for further information:

Phone: ☎ (603)778-2300
Toll Free: ☎ (888)597-9255
Fax: ☎ (603)778-9797
E-mail: sales@wallindustries.com
Web: www.wallindustries.com
Address: 37 Industrial Drive
Exeter, NH 03833

©2019 Wall Industries, Inc. Specifications subject to change without notice. Wall Industries is not responsible for typographical errors. The information contained herein is for informational purposes only. This information is provided by Wall Industries and we make no representations or warranties of any kind, express or implied, about the completeness, accuracy, reliability, suitability or availability with respect to the information contained in this document for any purpose. All product and manufacturer names are trademarks or registered trademarks of their respective companies.